

# Dual-in-line Switches

## Specifications:

|                        |  |
|------------------------|--|
| Contact rating:        | 50 V DC, 100 mA (non-switching); 24 V DC, 25 mA (switching)  |
| Contact resistance:    | < 50 mΩ  |
| Insulation resistance: | > 1000 MΩ at 100 V DC  |
| Capacity:              | < 5 pF between 2 poles   |
| Dielectric strength:   | 500 V, 50 Hz for the duration of 1 minute  |
| Operating temperature: | - 40° to + 85° C   |
| Electrical life:       | minimum 1000 operations per pole   |
| Shock resistance:      | contact interruption < 10 μsec with triple shock in all 6 directions,<br>shock conditions: 20 G, 11 msec duration (sine half wave) |
| Vibration:             | contact interruption: < 10 μsec at vibration test in accordance with<br>MIL-STD-202 D, method 204, condition C                     |
| Contacts:              | copper alloy, 0,3 μm gold-plated over 1 μm nickel  |
| Terminals:             | PC terminals, copper alloy, 0,2 μm gold-plated over 2 μm nickel  |
| Material:              | case: PPS; slide: PA   |
| Construction:          | case sealed<br>series 700: slide recessed, sealed with protective tape   |
| Mounting:              | on pc-board  |
| Slide position:        | OFF  |
| Soldering conditions:  | auto-soldering – max.: 5 sec 260° C  |

## Models:

### Series DSS 700 N

| Type      | Poles | Length (A) |
|-----------|-------|------------|
| DSS 701 N | 1     | 3,95 mm    |
| DSS 702 N | 2     | 6,50 mm    |
| DSS 703 N | 3     | 9,05 mm    |
| DSS 704 N | 4     | 11,60 mm   |
| DSS 705 N | 5     | 14,15 mm   |
| DSS 706 N | 6     | 16,70 mm   |
| DSS 707 N | 7     | 19,25 mm   |
| DSS 708 N | 8     | 21,80 mm   |
| DSS 710 N | 10    | 26,90 mm   |

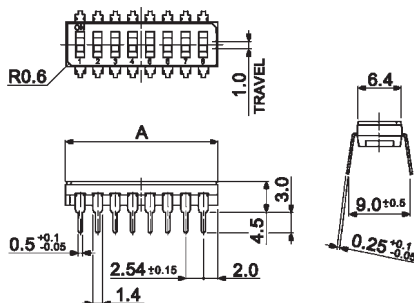

### Series DSS 800 N

| Type      | Poles | Length (A) |
|-----------|-------|------------|
| DSS 801 N | 1     | 3,95 mm    |
| DSS 802 N | 2     | 6,50 mm    |
| DSS 803 N | 3     | 9,05 mm    |
| DSS 804 N | 4     | 11,60 mm   |
| DSS 805 N | 5     | 14,15 mm   |
| DSS 806 N | 6     | 16,70 mm   |
| DSS 807 N | 7     | 19,25 mm   |
| DSS 808 N | 8     | 21,80 mm   |
| DSS 810 N | 10    | 26,90 mm   |

